

VDM12

Valve Driver Module 12 CANopen

FULL MANUAL

Introduction The Valve Driver Module is intended to be mounted on mobile or stationary machinery.

The VDM is responsible for driving proportional hydraulic valves and collecting sensor signals.

The module communicates with the system using the CANopen protocol.

The VDM module safety hardware and embedded SW is designed according to ISO 13849-1, performance level D, Category 3.

The CANopen version is not intended for safety applications due to limitations in the native design of CANopen.

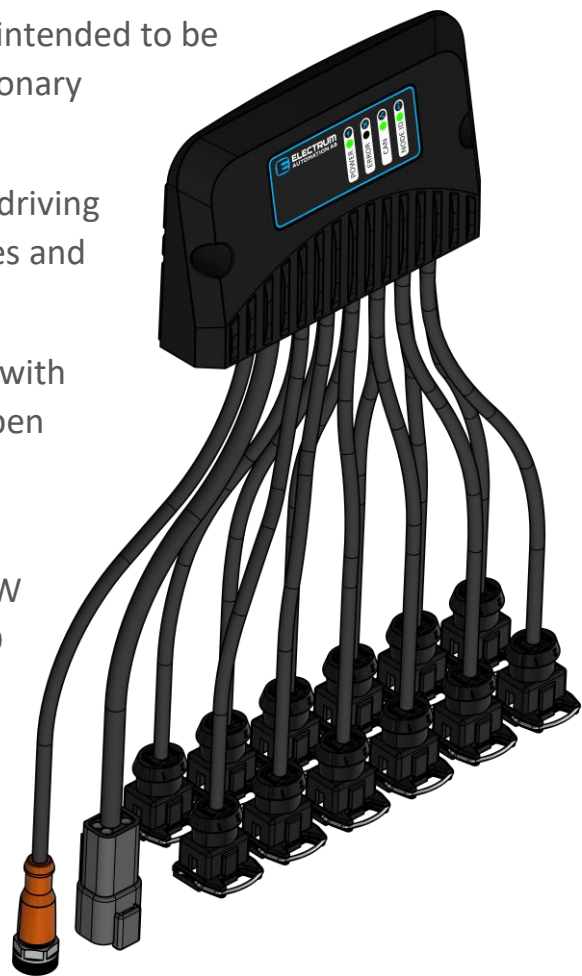

VDM Overview

Technical data

- Input voltage range 8 - 32V_{DC} operational supply voltage
- Designed to be mounted in direct vicinity of the valve block. Held in place with two M6 bolts
- Cable harness with valve connectors, sensor connectors and power/CAN connector
- A total of 2 analog 12bit inputs 4-20mA for pressure/ temp measurements
- A total of 12 current controlled 0-3A PWM outputs for valves with 1mA setpoint resolution
- Up to 16 different NODE-ID using different resistor values in external wiring harness
- 12 cables to valves, 1 cable to sensors, 1 cable for supply/CAN-ID offset /CAN-termination and CAN-bus

Mechanical data

- Operating ambient temperature -40° to +85°C. Critical components prone to aging specified for 105°C degrees or higher
- Dimensions, outline 136x87x26mm
- Housing material and cable jackets in oil resistant materials
- Hermetically sealed with polyurethane potting compound

Communication

- CANopen protocol
- CAN bit rate 50, 125, 250, 500 or 1000kbit/s
- The VDM module has a built in CAN termination 120ohm resistor which can be enabled with an external wire jumper
- LED indicators for power supply, CAN ID offset, CAN status and generic errors.



Test standards

- Immunity conducted interference ISO7637-2, pulse 1, 2a, 2b, 3a, 3b, 4, pulse 5: +202V
- Immunity to interfering fields ISO 11452-2, 250MHz-1GHz, 100V/m
- Current injection ISO 11452-4, 1MHz-250Mhz, 100mA
- Interference emission CISPR 25, 30MHz – 1GHz
- ESD ISO 10605, 8kV contact, 15kV air

Safety standard

- Hardware designed according to ISO 13849-1 PLd, Category 3
- No software support for safety

Table of content

1	About this document.....	4
1.1	Introduction.....	4
1.2	Terms, definitions, and abbreviated terms.....	4
1.2.1	VDMx	4
1.2.2	CAN master.....	4
1.3	Symbols	4
2	Precautions.....	5
3	Electrical characteristics	5
4	Absolute maximum ratings	6
5	Mechanical dimensions.....	7
6	Functional safety data	8
7	Warranty.....	8
8	Handling.....	8
8.1	Installation, commissioning, and maintenance.....	8
8.1.1	Installation	9
9	Design principle	11
9.1	Function limitations.....	11
9.1.1	Set-point error	11
9.1.2	Hydraulic system design	11
9.1.3	Hydraulic valve errors.....	11
9.2	Safe state	11
10	Functional description	12
10.1	Fuse protection.....	12
10.2	CAN ID input	12
10.3	CAN termination.....	12
10.4	Output loads.....	13
10.5	Block schematic	14
11	CAN bus	15
11.1	CAN Bit rate	15
12	Supply voltage	15
13	Status LED's	16
13.1	Error and Node ID LED flash pattern	16
14	Connectors	17
14.1	DTM04-08PA Male enumeration	17

14.2	M12 5pin A-coded Female enumeration	17
14.3	Junior Timer 2p Female enumeration	18
15	CAN protocol	19
15.1	Hardware structure	19
15.2	CANopen Object dictionary	20
15.3	CANopen EMCY objects.....	31
16	Declaration of conformity CE	33
17	Safety requirements for integrator to comply with	34
18	Document history	35
19	Contact us.....	36

1 About this document

1.1 Introduction

The instructions in this manual are to be used as a reference tool for the machine manufacturer's design, production, and service personnel to ensure a proper integration of the VDM module.

The user reading these instructions should have basic knowledge in working with electronic equipment.

1.2 Terms, definitions, and abbreviated terms

1.2.1 VDMx

VDM refers to Valve Driver Module. x refers to the number of available outputs. This is the product manual for the VDM.

1.2.2 CAN master

The CAN master refers to the CAN device which will be transmitting/receiving to/from the VDM and evaluating the data which the VDM unit transmits on the CAN bus.

1.3 Symbols

Sections in this document which defines a requirement for the safe use of the product are identified with a yellow box containing a warning icon, requirement identifier, header and description.

SREQ 0001

Example of a safety requirement



This is a safety requirement. Read and make sure you understand and comply with this requirement.

2 Precautions

SREQ 0002



All safety requirements shall be fulfilled

All safety requirements shall be fulfilled for the product to perform and behave as expected during its operational life.

SREQ 0003



Use within specification

The product shall only be used within its specified range.

3 Electrical characteristics

Parameter	Condition	Min.	Typ.	Max.	Unit
Operational voltage ⁽¹⁾		8		32	V _{DC}
Power consumption Idle ⁽²⁾	35V < V _{IN} > 8V		1		W
Operating temperature		-40		85	°C
Analog input voltage range	On sensor inputs	0		24	mA
Analog voltage input impedance	Fixed pull-down		180		Ω
PWM frequency		50	200	250	Hz
PWM duty-cycle		0		100	%
Output current high-side	Configurable	0		3	A
Maximum current low-side	Maximum summary current on all outputs			18	A
Overtemperature limit	Maximum internal temperature before disabling outputs			95	°C
Output current resolution	ADC resolution		12		bit
Output current resolution	ADC resolution		0.8		mA
Sensor supply current ⁽³⁾	Supply voltage current limited	0		160	mA

Note: 1. Module fully operational.
 2. Module fully operational. No signals connected to VDM except for VBB+ and GND.
 3. The sensor supply voltage potential is the same as VBB+.

4 Absolute maximum ratings

Parameter	Condition	Min.	Typ.	Max.	Unit
VBB input voltage ⁽¹⁾		0		35	V _{DC}
Input voltage CAN _L & CAN _H ⁽¹⁾		-36		36	V _{DC}
Storage temperature ⁽¹⁾		-55		125	°C
Max input voltage other pins ⁽¹⁾	All other pins except CAN and VBB	0		35	V _{DC}

Note: 1. Stresses beyond those listed under absolute maximum ratings may cause permanent damage to the device. These are stress ratings only, and functional operation of the device at these or any other conditions beyond those indicated under recommended operating conditions is not implied. Exposure to absolute-maximum-rated conditions for extended periods may affect device reliability.

6 Functional safety data

SREQ 0004

Safe state



This product shall only be used in systems which are in a safe state when the system is in a de-energized state. This product shall not be used where a function requires a constant operation.

SREQ 0005

CAN master responsibility



This product is intended to be connected to a CAN master. The CAN master shall be responsible for making sure that the overall system safety integrity is guaranteed in the event of a fault.

SREQ 0006

Expected restart interval



Since the VDM performs diagnostic tests of the hardware during bootup, this product shall only be used in applications where it is expected to be shut down or restarted within 48 hours of start-up.

7 Warranty

In the event of a malfunctioning VDM unit, the faulty VDM unit shall be sent to Electrum Automation AB for further investigation.

If the fault can be tracked to improper handling or usage, Electrum Automation AB reserves the right to claim the customer for costs involved in the warranty process.

8 Handling

8.1 Installation, commissioning, and maintenance

Installation, commissioning and maintenance of the VDM board shall be carried out by personnel with proper training. Personnel involved in installation, commissioning and maintenance shall be trained in such a manner that they do not contradict any of the requirements stated in this manual.

The VDM board itself does not require any maintenance. Modification or repair of the VDM shall not be carried out by third-party.

SREQ 0007

Proper training



Personnel involved in installation, commissioning and maintenance shall be trained in such a manner that their actions do not contradict any of the requirements stated in this manual.

SREQ 0008

Repair



A damaged product shall not be used and may only be repaired by Electrum Automation AB.

8.1.1 Installation

The VDM shall be mounted on a flat surface and must not be exposed to any torsional forces or mechanical stress.

Improper VDM mounting

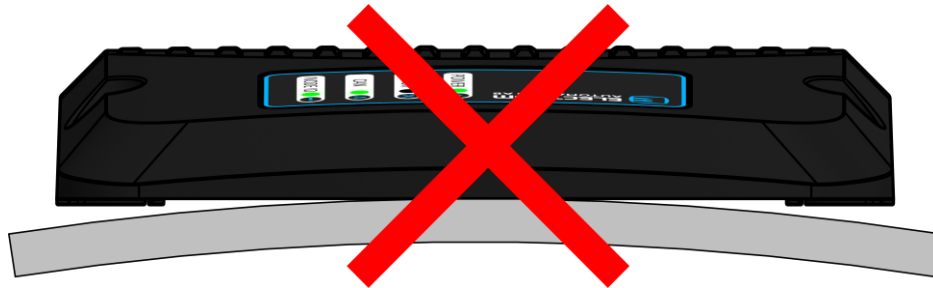

Proper VDM mounting



If the mounting location renders the VDM susceptible to moisture, water or other fluids, the VDM shall be oriented in a way where the cables are **not** pointing upwards according to the illustration below, this will prevent water and other fluids from possibly penetrating the potting compound over time.

Improper VDM orientation

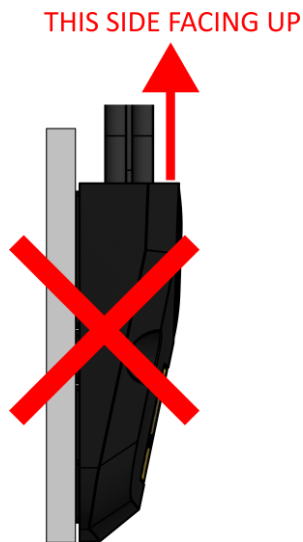

Proper VDM orientation

THIS SIDE FACING UP

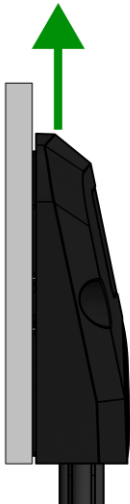

THIS SIDE FACING UP



THIS SIDE FACING UP

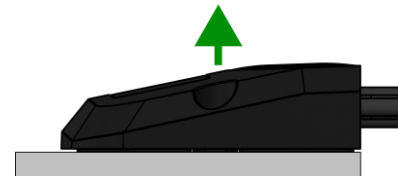

9 Design principle

The VDM implements Category 3 as described in ISO 13849-1. This means that the hardware for the VDM is redundant. Channel 1 is responsible for controlling the high-side switches. Channel 2 is responsible for controlling the low side switch.

The VDM is designed for controlling proportional and ON/OFF hydraulic valves in 12V and 24V systems with CAN bus communication.

The proportional valves are controlled by adjusting the current through each valve, which enables the valve to be controlled from fully closed to fully open.

The ON/OFF valves are controlled by applying +VBB over the valve which turns the valve fully open. The VDM module acts as a slave on the CAN bus and requires a CAN master to tell the VDM module when and which valve to enable, as well as how much current should flow through each valve.

The safe state of the system shall always be to restrict or disable any dangerous movements in case the VDM or the CAN master detects a fault.

9.1 Function limitations

9.1.1 Set-point error

Due to the design of the VDM module, the module cannot in the presence of all conceivable faults guarantee that the set-point current is equal to the actual-current.

The outputs may or may not require external monitoring, at a system level depending on the system safety requirements.

Example: If a hydraulic valve is connected to one of the VDM outputs which in turn controls the machine propulsion, and a doubled current through this valve equals a doubled machine velocity, which for this particular system is deemed unacceptable from a safety point of view. A speed sensor should be used as a monitoring channel which ensures that the actual velocity equals the expected velocity.

This system level safety evaluation shall be performed on a case-to-case basis depending on which kind of functions will be attached to the VDM outputs.

9.1.2 Hydraulic system design

A presumption for all hydraulic valves used along with the VDM module is that all valves connected to the VDM outputs are in a safe state when no power is applied to the valves.

9.1.3 Hydraulic valve errors

Since the VDM only has valve current feedback, and not a valve position feedback, there is no guarantee that for a given set-current, the valve will be in a known position. The hydraulic valve could be jammed, and still draw current as if it was working properly.

9.2 Safe state

The safe state of the VDM is when all outputs are in a de-energized state (valves fully closed).

10 Functional description

10.1 Fuse protection

The supply voltage to the VDM shall be protected with a fuse ranging from 1-20A depending on the output current needs and the external wiring dimensions. The fuse will protect the VDM module and wiring in case of device malfunction, overvoltage, or reverse voltage.

10.2 CAN ID input

The VDM requires that an external id resistor is connected to the wiring harness. If no resistor is connected or the ID input is shorted to ground, no CAN id is available, and the ID LED will be red. The CAN ID input is only sampled during bootup, the VDM will **not** change CAN ID during runtime.

The CAN ID input is not part of the safety function, this means that the integrator of the VDM module shall take measures to ensure that a dangerous situation does not arise if the VDM were to misinterpret the resistor input.

SREQ 0009 Notes about the CAN ID input.



The integrator of the VDM module shall design the system in such a way that a dangerous situation does not arise if the VDM were to misinterpret the CAN ID resistor input, thus possibly starting to transmit data on a different CAN identifier.

ID resistance value (ohm)	Channel 1 CANopen Node-id	Channel 2 CANopen Node-id	ID LED State	IEC60063 E-series
Short circuit	Error	Error	RED	-
294 ohm	70	71	GREEN x 1	E96, E192
590 ohm	72	73	GREEN x 2	E48, E96, E192
976 ohm	74	75	GREEN x 3	E96, E192
1500 ohm	76	77	GREEN x 4	E6, E12, E24, E48, E96, E192
2230 ohm	78	79	GREEN x 5	E192
3360 ohm	80	81	GREEN x 6	E192
5300 ohm	82	83	GREEN x 7	E192
9530 ohm	84	85	GREEN x 8	E48, E96, E192
Open circuit	Error	Error	RED	-

10.3 CAN termination

The VDM has a built in 120ohm CAN termination resistor. This termination resistor is enabled by adding a jumper wire between the CAN_TERMINATION pins.

10.4 Output loads

The VDM has a built-in flyback diode for all current controlled outputs.
The VDM will automatically detect the presence of potential external flyback diodes and disable the output in case an external flyback diode is detected.
No external flyback diode shall be present.

Only inductive loads shall be connected to the current controlled outputs.
Inductive or resistive loads are supported for raw PWM controlled outputs.

10.5 Block schematic

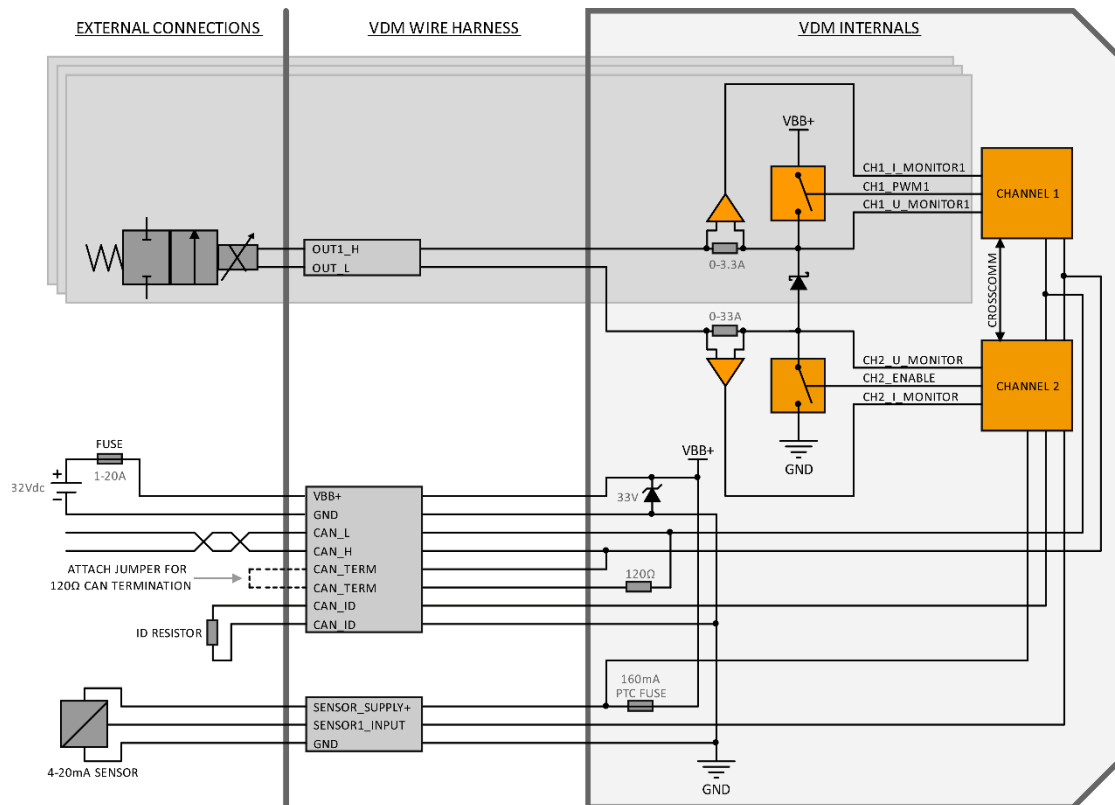

11 CAN bus

The VDM supports CAN 2.0A, CAN 2.0B and CAN FD. The VDM communicates using CAN 2.0A as specified in CANopen (CiA 301).

11.1 CAN Bit rate

The CAN bit rate can be configured from the object dictionary.

12 Supply voltage

The VDM is suitable for both +12V and +24V applications. Some degradation of the device can occur during cold-crank in +12V systems. But the VDM operation is automatically restored once the system voltage settles again.

13 Status LED's

The VDM module has four LED's which can be used to troubleshoot the module in case of device malfunction. The VDM should be mounted in such a way that these LED's are easily accessible for ease of troubleshooting. In the event where multiple errors are active at the same time, the error with the lowest amount of flashes will be prioritized.

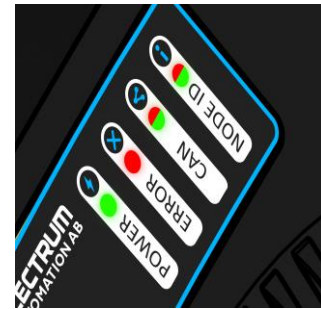

Description		
Power	Off	Module not powered or internal HW/SW failure.
	On	VBB+ voltage is above 5.8V.
Error	Off	No error detected.
	1 flash	Error: CAN error passive or bus off detected. The error will remain until the power is cycled.
	2 flashes	Error: Internal watchdog timeout detected. The error will remain until the power is cycled.
	3 flashes	Error: Bootup test of VDM hardware failed. Outputs are disabled. The error will remain until the power is cycled and a new bootup test is performed.
	4 flashes	Error: Output was stuck on. Outputs are disabled. The error will remain until the power is cycled.
	5 flashes	Error: High side wiring short circuit detected. Outputs are disabled. The error will remain until the power is cycled.
	6 flashes	Error: Current comparison between CH1 and CH2 failed, too large deviance. Outputs are disabled. The error will remain until the power is cycled.
	7 flashes	Error: One or multiple outputs has detected an external flyback diode or internal loss of the flyback diode, alternatively a resistive load is connected. The specific output is disabled. The error will remain until the power is cycled.
	8 flashes	Error: Low side current measurement was saturated. Too much current is being drawn. The error will disappear as soon as less current is flowing through the common low side output.
	9 flashes	Error: Internal overtemperature. The outputs are temporarily disabled. The error will disappear as soon as the temperature drops.
	10 flashes	Error: Short circuit is present. The error will disappear as soon as the output is turned off or the short-circuit is removed.
	11 flashes	Error: CAN overrun detected. The VDM is unable to receive/transmit all CAN messages on the bus. The error will remain until the power is cycled.
12 flashes	Error: Short circuit has been present at least once. The error will remain until the power is cycled.	
CAN	Off	The module has not yet booted.
	Blinking	The CAN LED will toggle on/off green for every successfully transmitted or received CAN packet.
	On	The CAN LED will turn red if CAN error warning, error passive or bus off is detected.
Node ID	Off	The module has not yet booted.
	Flashes	Node id offset 0 = 1 flash. Node id offset 7 = 8 flashes.
	On	No ID resistor detected, or ID resistor input short circuited to ground.

13.1 Error and Node ID LED flash pattern

Below is an illustration of the flash pattern of the error LED and Node ID led.

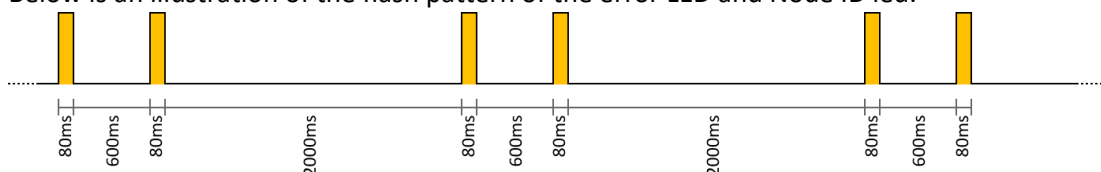

14 Connectors

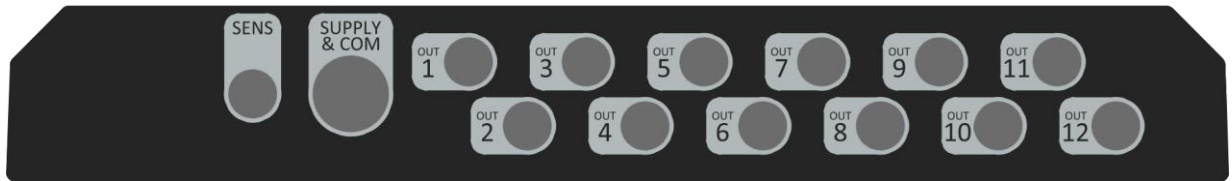

14.1 DTM04-08PA Male enumeration

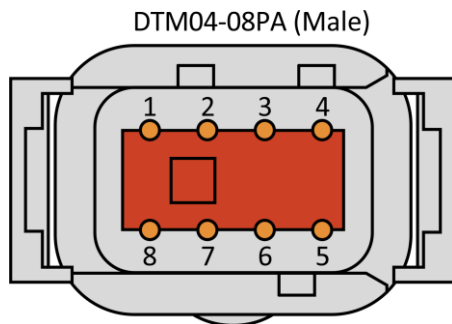

Connector	Pin number	Pin identifier	Note
CAN IN	1	VBB+	+24V nominal
	2	GND	Ground
	3	CAN _H	CAN bus high
	4	CAN _L	CAN bus low
	5	CAN_ID	Add resistor between pin 5 and 6 to set CAN ID offset
	6	CAN_ID	Add resistor between pin 5 and 6 to set CAN ID offset
	7	CAN_TERM	Add jumper wire between pin 7 and 8 to enable CAN termination
	8	CAN_TERM	Add jumper wire between pin 7 and 8 to enable CAN termination

14.2 M12 5pin A-coded Female enumeration

M12 5pin A-coded (Female)

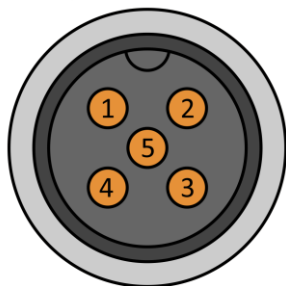

Connector	Pin number	Pin identifier	Note
SENS1/SENS2	1	SENSOR_SUPPLY+	VBB+ output current limited to 160mA.
	2	SENSOR1_INPUT	4-20mA input from sensor 1
	3	GND	Ground
	4	SENSOR2_INPUT	4-20mA input from sensor 2
	5	NC	Not connected

14.3 Junior Timer 2p Female enumeration

Junior Timer 2p (Female)



Connector	Pin number	Pin identifier	Note
1-12	1	OUT1_H – OUT12_H	Individual current controlled output from channel 1
	2	OUT_L	Common ground controlled from channel 2

15 CAN protocol

15.1 Hardware structure

The VDM module acts as one node on the CAN bus, even if there are two physical nodes on the bus. Channel 1 is the one with object dictionary and the module the CANopen master transmit and read information from. Channel 2 is only responding to bootloader commands, used for changing the software in the slave processor. They both operate on the same physical CAN bus. Channel 2 node-id will always be channel 1 node-id + 1. The node-id is determined by the CAN ID resistor input. There are no writable or readable indexes in channel 2.

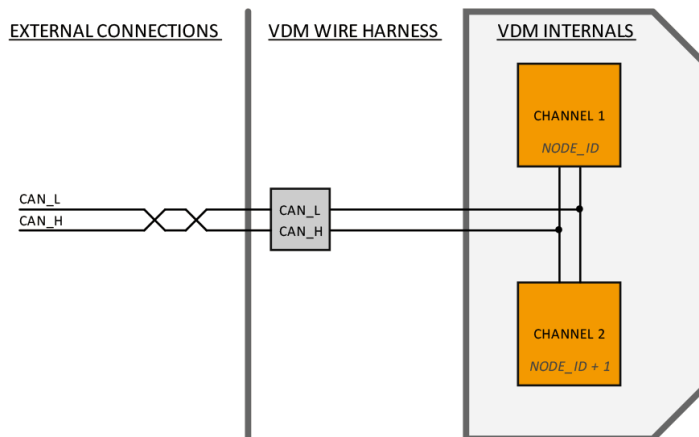

15.2 CANopen Object dictionary

Index	Sub-index	Name	Type	Default	Description	Mappable	Saveable
0x1000	0x00	Device type	ro u32	0x000460C9	Profile 401, Analogue inputs and outputs, binary and analogue		
0x1001	0x00	Error register	ro u8	0x00			
0x1005	0x00	COB-ID SYNC message	rw u32	0x00000080			x
0x1008	0x00	Device name	ro str	VDM12			
0x1009	0x00	Hardware version	ro str	X	Starting at char 'A'.		
0x100A	0x00	Software version	ro str	x.y.z	Starting at "1.0.0"		
0x1010	0x00	Number of save options	ro u8	0x01	Number of entries		
	0x01	Save parameter	rw u32	0x00000001	0x00000000 = No save. 0x00000001 = Saving all parameters after string "save" is written to this entry. 0x00000002 = Auto store.		x
0x1011	0x00	Number of restore options	ro u8	0x01	Number of entries		
	0x01	Restore default parameters	rw u32	0x00000001	Restores all parameters to default values if string 'load' is written to this entry. An NMT reset needs to be issued in order to load the default parameters.		
0x1014	0x00	COB-ID EMCY	rw u32	0x80000080+\$NODEID	Module generates EMCY messages (bit 31=0)		x
0x1016	0x00	Number of monitored devices	ro u8	0x01	Number of entries		
	0x01	Consumer heartbeat time	rw u32	0x00000000	Heartbeat monitoring time for node n monitoring. 0x0nntttt = monitoring time (ms) 0x0nntttt = node number If nn or tttt = 0, no monitoring is carried out.		x
0x1017	0x00	Producer heartbeat time	rw u16	0x00FA	Time interval (ms) where the module generates a producer heartbeat.		x
0x1018	0x00	Number of identity objects	ro u8	0x04	Number of entries		
	0x01	Vendor ID	ro u32	0x00000356	Electrum Automation AB		
	0x02	Product code	ro u32	0x00000000	Always 0		
	0x03	Revision number	ro u32	0x00000000	Always 0		
	0x04	Serial number	ro u32	0x????????	Unique processor identifier		

Index	Sub-index	Name	Type	Default	Description	Mappable	Saveable
0x1400	0x00	Receive PDO 1 Communication Parameter	ro u8	0x05	Number of entries		
	0x01	COB-ID used by PDO	rw u32	0x00000200 + \$NODEID			x
	0x02	Transmission type	rw u8	1			x
	0x03	Inhibit time	rw u16	300			x
	0x05	Event timer	rw u16	100			x
0x1401	0x00	Receive PDO 2 Communication Parameter	ro u8	0x05	Number of entries		
	0x01	COB-ID used by PDO	rw u32	0x00000300 + \$NODEID			x
	0x02	Transmission type	rw u8	1			x
	0x03	Inhibit Time	rw u16	300			x
	0x05	Event timer	rw u16	100			x
0x1402	0x00	Receive PDO 3 Communication Parameter	ro u8	0x05	Number of entries		
	0x01	COB-ID used by PDO	rw u32	0x00000400 + \$NODEID			x
	0x02	Transmission type	rw u8	1			x
	0x03	Inhibit time	rw u16	300			x
	0x05	Event timer	rw u16	100			x
0x1403	0x00	Receive PDO 4 Communication Parameter	ro u8	0x05	Number of entries		
	0x01	COB-ID used by PDO	rw u32	0x80000500 + \$NODEID			x
	0x02	Transmission type	rw u8	0			x
	0x03	Inhibit time	rw u16	0			x
	0x05	Event timer	rw u16	0			x

Index	Sub-index	Name	Type		Default	Description	Mappable	Saveable
0x1600	0x00	Receive PDO 1 Mapping Parameter	rw	u8	0x00	Number of mapped objects		x
	0x01	PDO Mapping Entry 1	rw	u32	0x40000110	Output 1 set value		x
	0x02	PDO Mapping Entry 2	rw	u32	0x40000210	Output 2 set value		x
	0x03	PDO Mapping Entry 3	rw	u32	0x40000310	Output 3 set value		x
	0x04	PDO Mapping Entry 4	rw	u32	0x40000410	Output 4 set value		x
0x1601	0x00	Receive PDO 2 Mapping Parameter	rw	u8	0x00	Number of mapped objects		x
	0x01	PDO Mapping Entry 1	rw	u32	0x40000510	Output 5 set value		x
	0x02	PDO Mapping Entry 2	rw	u32	0x40000610	Output 6 set value		x
	0x03	PDO Mapping Entry 3	rw	u32	0x40000710	Output 7 set value		x
	0x04	PDO Mapping Entry 4	rw	u32	0x40000810	Output 8 set value		x
0x1602	0x00	Receive PDO 3 Mapping Parameter	rw	u8	0x00	Number of mapped objects		x
	0x01	PDO Mapping Entry 1	rw	u32	0x40000910	Output 9 set value		x
	0x02	PDO Mapping Entry 2	rw	u32	0x40000A10	Output 10 set value		x
	0x03	PDO Mapping Entry 3	rw	u32	0x40000B10	Output 11 set value		x
	0x04	PDO Mapping Entry 4	rw	u32	0x40000C10	Output 12 set value		x
0x1603	0x00	Receive PDO 4 Mapping Parameter	rw	u8	0x00	Number of mapped objects		x
	0x01	PDO Mapping Entry 1	rw	u32	0x00000000			x
	0x02	PDO Mapping Entry 2	rw	u32	0x00000000			x
	0x03	PDO Mapping Entry 3	rw	u32	0x00000000			x
	0x04	PDO Mapping Entry 4	rw	u32	0x00000000			x
	0x05	PDO Mapping Entry 5	rw	u32	0x00000000			x
	0x06	PDO Mapping Entry 6	rw	u32	0x00000000			x
	0x07	PDO Mapping Entry 7	rw	u32	0x00000000			x
	0x08	PDO Mapping Entry 8	rw	u32	0x00000000			x

Index	Sub-index	Name	Type		Default	Description	Mappable	Saveable
0x1800	0x00	Transmit PDO 1 Communication Parameter	ro	u8	0x05	Number of entries		
	0x01	COB-ID used by PDO	rw	u32	0x00000180 + \$NODEID			x
	0x02	Transmission type	rw	u8	255	Event-driven		x
	0x03	Inhibit Time	rw	u16	300	Inhibit time in multiples of 0.1ms		x
	0x05	Event timer	rw	u16	50	Transmission rate in milliseconds		x
0x1801	0x00	Transmit PDO 2 Communication Parameter	ro	u8	0x05	Number of entries		
	0x01	COB-ID used by PDO	rw	u32	0x00000280 + \$NODEID			x
	0x02	Transmission type	rw	u8	255	Event-driven		x
	0x03	Inhibit time	rw	u16	300	Inhibit time in multiples of 0.1ms		x
	0x05	Event timer	rw	u16	50	Transmission rate in milliseconds		x
0x1802	0x00	Transmit PDO 3 Communication Parameter	ro	u8	0x05	Number of entries		
	0x01	COB-ID used by PDO	rw	u32	0x80000380 + \$NODEID			x
	0x02	Transmission type	rw	u8	255	Event-driven		x
	0x03	Inhibit time	rw	u16	300	Inhibit time in multiples of 0.1ms		x
	0x05	Event timer	rw	u16	100	Transmission rate in milliseconds		x
0x1803	0x00	Transmit PDO 4 Communication Parameter	ro	u8	0x05	Number of entries		
	0x01	COB-ID used by PDO	rw	u32	0x80000480 + \$NODEID			x
	0x02	Transmission type	rw	u8	255			x
	0x03	Inhibit time	rw	u16	300	Inhibit time in multiples of 0.1ms		x
	0x05	Event timer	rw	u16	100	Transmission rate in milliseconds		x

Index	Sub-index	Name	Type		Default	Description	Mappable	Saveable
0x1A00	0x00	Transmit PDO 1 Mapping Parameter	rw	u8	0x02	Number of mapped objects		x
	0x01	PDO Mapping Entry 1	rw	u32	0x20010020	VDM identity		x
	0x02	PDO Mapping Entry 2	rw	u32	0x50020020	Output x status		x
0x1A01	0x00	Transmit PDO 2 Mapping Parameter	rw	u8	0x02	Number of mapped objects		x
	0x01	PDO Mapping Entry 1	rw	u32	0x50010510	Sensor input 1		x
	0x02	PDO Mapping Entry 2	rw	u32	0x50010610	Sensor input 2		x
0x1A02	0x00	Transmit PDO 3 Mapping Parameter	rw	u8	0x00	Number of mapped objects		x
0x1A03	0x00	Transmit PDO 4 Mapping Parameter	rw	u8	0x00	Number of mapped objects		x

Index	S-idx	Name	Type	Default	Description	Mappable	Saveable
0x2000	0x00	VDM identity	ro u8	0x20	Number of identity objects		
	0x01	VDM identity 1	rw u32	0x00000000	Identity entry which can be used by the end user	x	x
	0x02	VDM identity 2	rw u32	0x00000000	Identity entry which can be used by the end user	x	x
	0x03	VDM identity 3	rw u32	0x00000000	Identity entry which can be used by the end user	x	x
	0x04	VDM identity 4	rw u32	0x00000000	Identity entry which can be used by the end user	x	x
	0x05	VDM identity 5	rw u32	0x00000000	Identity entry which can be used by the end user	x	x
	0x06	VDM identity 6	rw u32	0x00000000	Identity entry which can be used by the end user	x	x
	0x07	VDM identity 7	rw u32	0x00000000	Identity entry which can be used by the end user	x	x
	0x08	VDM identity 8	rw u32	0x00000000	Identity entry which can be used by the end user	x	x
	0x09	VDM identity 9	rw u32	0x00000000	Identity entry which can be used by the end user	x	x
	0x0A	VDM identity 10	rw u32	0x00000000	Identity entry which can be used by the end user	x	x
	0x0B	VDM identity 11	rw u32	0x00000000	Identity entry which can be used by the end user	x	x
	0x0C	VDM identity 12	rw u32	0x00000000	Identity entry which can be used by the end user	x	x
	0x0D	VDM identity 13	rw u32	0x00000000	Identity entry which can be used by the end user	x	x
	0x0E	VDM identity 14	rw u32	0x00000000	Identity entry which can be used by the end user	x	x
	0x0F	VDM identity 15	rw u32	0x00000000	Identity entry which can be used by the end user	x	x
	0x10	VDM identity 16	rw u32	0x00000000	Identity entry which can be used by the end user	x	x
	0x11	VDM identity 17	rw u32	0x00000000	Identity entry which can be used by the end user	x	x
	0x12	VDM identity 18	rw u32	0x00000000	Identity entry which can be used by the end user	x	x
	0x13	VDM identity 19	rw u32	0x00000000	Identity entry which can be used by the end user	x	x
	0x14	VDM identity 20	rw u32	0x00000000	Identity entry which can be used by the end user	x	x
	0x15	VDM identity 21	rw u32	0x00000000	Identity entry which can be used by the end user	x	x
	0x16	VDM identity 22	rw u32	0x00000000	Identity entry which can be used by the end user	x	x
	0x17	VDM identity 23	rw u32	0x00000000	Identity entry which can be used by the end user	x	x
	0x18	VDM identity 24	rw u32	0x00000000	Identity entry which can be used by the end user	x	x
	0x19	VDM identity 25	rw u32	0x00000000	Identity entry which can be used by the end user	x	x
	0x1A	VDM identity 26	rw u32	0x00000000	Identity entry which can be used by the end user	x	x
	0x1B	VDM identity 27	rw u32	0x00000000	Identity entry which can be used by the end user	x	x
	0x1C	VDM identity 28	rw u32	0x00000000	Identity entry which can be used by the end user	x	x
	0x1D	VDM identity 29	rw u32	0x00000000	Identity entry which can be used by the end user	x	x
	0x1E	VDM identity 30	rw u32	0x00000000	Identity entry which can be used by the end user	x	x
	0x1F	VDM identity 31	rw u32	0x00000000	Identity entry which can be used by the end user	x	x
	0x20	VDM identity 32	rw u32	0x00000000	Identity entry which can be used by the end user	x	x
0x2001	0x00	VDM identity	ro u32	0x00000000	If mapped to a TX PDO, this entry will loop through index 0x2000, each time incrementing sub-index 0x01-0x20. 0xssdddddd = sub-index 0x01-0x20 0xssdddddd = Lower 24 bits of identity x data	x	

Index	S-idx	Name	Type		Default	Description	Mappable	Saveable
0x20F2	0x00	CAN baudrate	rw	u16	250	Supported baudrates: 50 = 50kbit/s 125 = 125kbit/s 250 = 250kbit/s 500 = 500kbit/s 1000 = 1Mbit/s		x
0x20F3	0x00	CAN baudrate	rw	u16	250	Baudrate must be written to index 20F2 first, and then written to this index. Note: When correct values has been written first to Index 0x20F2 and then to 0x20F3 the new baud rate is automatically saved regardless of the setting in index 0x1010, sub-index 0x01. The new baud rate will be used after a reboot of the module.		x

Index	S-idx	Name	Type	Default	Description	Mappable	Saveable
0x3000	0x00	Output type	ro	u8	0x0C	Number of outputs	
	0x01	Output 1 is PWM	rw	u8	0	0=Output is current controlled, 1=Output is PWM	x
	0x02	Output 2 is PWM	rw	u8	0	0=Output is current controlled, 1=Output is PWM	x
	0x03	Output 3 is PWM	rw	u8	0	0=Output is current controlled, 1=Output is PWM	x
	0x04	Output 4 is PWM	rw	u8	0	0=Output is current controlled, 1=Output is PWM	x
	0x05	Output 5 is PWM	rw	u8	0	0=Output is current controlled, 1=Output is PWM	x
	0x06	Output 6 is PWM	rw	u8	0	0=Output is current controlled, 1=Output is PWM	x
	0x07	Output 7 is PWM	rw	u8	0	0=Output is current controlled, 1=Output is PWM	x
	0x08	Output 8 is PWM	rw	u8	0	0=Output is current controlled, 1=Output is PWM	x
	0x09	Output 9 is PWM	rw	u8	0	0=Output is current controlled, 1=Output is PWM	x
	0x0A	Output 10 is PWM	rw	u8	0	0=Output is current controlled, 1=Output is PWM	x
	0x0B	Output 11 is PWM	rw	u8	0	0=Output is current controlled, 1=Output is PWM	x
	0x0C	Output 12 is PWM	rw	u8	0	0=Output is current controlled, 1=Output is PWM	x
0x3001	0x00	Output Kp factor	ro	u8	0x0C	Number of outputs	
	0x01	Output 1 Kp ¹	rw	u16	1000	Kp factor for regulator in multiples of 0.001	x
	0x02	Output 2 Kp ¹	rw	u16	1000	Kp factor for regulator in multiples of 0.001	x
	0x03	Output 3 Kp ¹	rw	u16	1000	Kp factor for regulator in multiples of 0.001	x
	0x04	Output 4 Kp ¹	rw	u16	1000	Kp factor for regulator in multiples of 0.001	x
	0x05	Output 5 Kp ¹	rw	u16	1000	Kp factor for regulator in multiples of 0.001	x
	0x06	Output 6 Kp ¹	rw	u16	1000	Kp factor for regulator in multiples of 0.001	x
	0x07	Output 7 Kp ¹	rw	u16	1000	Kp factor for regulator in multiples of 0.001	x
	0x08	Output 8 Kp ¹	rw	u16	1000	Kp factor for regulator in multiples of 0.001	x
	0x09	Output 9 Kp ¹	rw	u16	1000	Kp factor for regulator in multiples of 0.001	x
	0x0A	Output 10 Kp ¹	rw	u16	1000	Kp factor for regulator in multiples of 0.001	x
	0x0B	Output 11 Kp ¹	rw	u16	1000	Kp factor for regulator in multiples of 0.001	x
	0x0C	Output 12 Kp ¹	rw	u16	1000	Kp factor for regulator in multiples of 0.001	x
0x3002	0x00	Output Ki factor	ro	u8	0x0C	Number of outputs	
	0x01	Output 1 Ki ¹	rw	u16	1000	Ki factor for regulator in multiples of 0.001	x
	0x02	Output 2 Ki ¹	rw	u16	1000	Ki factor for regulator in multiples of 0.001	x
	0x03	Output 3 Ki ¹	rw	u16	1000	Ki factor for regulator in multiples of 0.001	x
	0x04	Output 4 Ki ¹	rw	u16	1000	Ki factor for regulator in multiples of 0.001	x
	0x05	Output 5 Ki ¹	rw	u16	1000	Ki factor for regulator in multiples of 0.001	x
	0x06	Output 6 Ki ¹	rw	u16	1000	Ki factor for regulator in multiples of 0.001	x
	0x07	Output 7 Ki ¹	rw	u16	1000	Ki factor for regulator in multiples of 0.001	x
	0x08	Output 8 Ki ¹	rw	u16	1000	Ki factor for regulator in multiples of 0.001	x
	0x09	Output 9 Ki ¹	rw	u16	1000	Ki factor for regulator in multiples of 0.001	x
	0x0A	Output 10 Ki ¹	rw	u16	1000	Ki factor for regulator in multiples of 0.001	x
	0x0B	Output 11 Ki ¹	rw	u16	1000	Ki factor for regulator in multiples of 0.001	x
	0x0C	Output 12 Ki ¹	rw	u16	1000	Ki factor for regulator in multiples of 0.001	x

Note: 1. Only relevant for current controlled outputs

Index	S-idx	Name	Type		Default	Description	Mappable	Saveable
0x3003	0x00	PWM frequency ¹	rw	u8	200	Defines the PWM frequency in Hz. Valid range is 50-250Hz. The module will automatically reboot when the PWM frequency has been changed.		x
0x3004	0x00	Ripple settings	ro	u8	0x03	Number of ripple settings		
	0x01	Ripple frequency divider ¹	rw	u8	0	Ripple_frequency = (PWM frequency ⁻¹ *Ripple frequency divider*2) ⁻¹ . A value of 0 disables the ripple.		x
	0x02	Ripple amplitude ¹	rw	u8	0	Defines the ripple amplitude. 0-255 corresponds to 0-100% ripple amplitude. A value of 0 disables the ripple.		x
	0x03	Ripple timeout ¹	rw	u16	0	Defines the ripple timeout, a value of 0 disables the ripple timeout feature. If this value differs from 0, this parameter becomes a millisecond timer which defines how long the ripple should be applied to the output after the value of the set current has been changed		x

Note: 1. Only relevant for current control outputs

Index	S-idx	Name	Type	Default	Description	Mappable	Saveable
0x4000	0x00	Output set value	ro u8	0x0C	Number of outputs		
	0x01	Output 1 set value ¹	rw u16	0	Configures the desired set value for output 1	x	
	0x02	Output 2 set value ¹	rw u16	0	Configures the desired set value for output 2	x	
	0x03	Output 3 set value ¹	rw u16	0	Configures the desired set value for output 3	x	
	0x04	Output 4 set value ¹	rw u16	0	Configures the desired set value for output 4	x	
	0x05	Output 5 set value ¹	rw u16	0	Configures the desired set value for output 5	x	
	0x06	Output 6 set value ¹	rw u16	0	Configures the desired set value for output 6	x	
	0x07	Output 7 set value ¹	rw u16	0	Configures the desired set value for output 7	x	
	0x08	Output 8 set value ¹	rw u16	0	Configures the desired set value for output 8	x	
	0x09	Output 9 set value ¹	rw u16	0	Configures the desired set value for output 9	x	
	0x0A	Output 10 set value ¹	rw u16	0	Configures the desired set value for output 10	x	
	0x0B	Output 11 set value ¹	rw u16	0	Configures the desired set value for output 11	x	
	0x0C	Output 12 set value ¹	rw u16	0	Configures the desired set value for output 12	x	
0x5000	0x00	Summary current	ro U8	0x02	Number of summary current	x	
	0x01	High-side summary current	ro u16	0	Reports the total current in mA which is passing through all the high-side switches	x	
	0x02	Low-side summary current	ro u16	0	Reports the total current in mA which is passing through all the low-side switches	x	

Note: 1. If the output is configured as a current controlled output, the set value is the desired current in mA, 0-3000mA.
 If the output is configured as a PWM output, the set value is the desired PWM duty-cycle 0x0000-0xFFFF

Index	S-idx	Name	Type		Default	Description	Mappable	Saveable																												
0x5001	0x00	Output actual current	ro	u8	0x0C	Number of outputs																														
	0x01	Output 1 actual current	ro	u16	-	Reports the actual current on output 1 in mA	x																													
	0x02	Output 2 actual current	ro	u16	-	Reports the actual current on output 2 in mA	x																													
	0x03	Output 3 actual current	ro	u16	-	Reports the actual current on output 3 in mA	x																													
	0x04	Output 4 actual current	ro	u16	-	Reports the actual current on output 4 in mA	x																													
	0x05	Output 5 actual current	ro	u16	-	Reports the actual current on output 5 in mA	x																													
	0x06	Output 6 actual current	ro	u16	-	Reports the actual current on output 6 in mA	x																													
	0x07	Output 7 actual current	ro	u16	-	Reports the actual current on output 7 in mA	x																													
	0x08	Output 8 actual current	ro	u16	-	Reports the actual current on output 8 in mA	x																													
	0x09	Output 9 actual current	ro	u16	-	Reports the actual current on output 9 in mA	x																													
	0x0A	Output 10 actual current	ro	u16	-	Reports the actual current on output 10 in mA	x																													
	0x0B	Output 11 actual current	ro	u16	-	Reports the actual current on output 11 in mA	x																													
	0x0C	Output 12 actual current	ro	u16	-	Reports the actual current on output 12 in mA	x																													
0x5002	0x00	Output x status	ro	u32	-	<table border="1"> <tr> <td><i>Bit 0-11</i></td> <td>Info: Actual current in mA</td> </tr> <tr> <td><i>Bit 12</i></td> <td>Info: Output type is PWM</td> </tr> <tr> <td><i>Bit 13</i></td> <td>Info: No load detected</td> </tr> <tr> <td><i>Bit 14</i></td> <td>Warning: Regulator not stable¹</td> </tr> <tr> <td><i>Bit 15</i></td> <td>Warning: Short circuit²</td> </tr> <tr> <td><i>Bit 16</i></td> <td>Warning: Overtemperature²</td> </tr> <tr> <td><i>Bit 17</i></td> <td>Warning: Overcurrent²</td> </tr> <tr> <td><i>Bit 18</i></td> <td>Error: Flyback diode³</td> </tr> <tr> <td><i>Bit 19</i></td> <td>Error: High-side stuck on³</td> </tr> <tr> <td><i>Bit 20</i></td> <td>Error: High-side wiring³</td> </tr> <tr> <td><i>Bit 21</i></td> <td>Error: Bootup test failed³</td> </tr> <tr> <td><i>Bit 22</i></td> <td>Error: Delta summary current³</td> </tr> <tr> <td><i>Bit 23-27</i></td> <td>Reserved (0)</td> </tr> <tr> <td><i>Bit 28-31</i></td> <td>Output number x. If mapped to a PDO, x will increase with 1 (up to 11 then back to 0 again) every time this entry is transmitted.</td> </tr> </table>	<i>Bit 0-11</i>	Info: Actual current in mA	<i>Bit 12</i>	Info: Output type is PWM	<i>Bit 13</i>	Info: No load detected	<i>Bit 14</i>	Warning: Regulator not stable ¹	<i>Bit 15</i>	Warning: Short circuit ²	<i>Bit 16</i>	Warning: Overtemperature ²	<i>Bit 17</i>	Warning: Overcurrent ²	<i>Bit 18</i>	Error: Flyback diode ³	<i>Bit 19</i>	Error: High-side stuck on ³	<i>Bit 20</i>	Error: High-side wiring ³	<i>Bit 21</i>	Error: Bootup test failed ³	<i>Bit 22</i>	Error: Delta summary current ³	<i>Bit 23-27</i>	Reserved (0)	<i>Bit 28-31</i>	Output number x. If mapped to a PDO, x will increase with 1 (up to 11 then back to 0 again) every time this entry is transmitted.	x	
<i>Bit 0-11</i>	Info: Actual current in mA																																			
<i>Bit 12</i>	Info: Output type is PWM																																			
<i>Bit 13</i>	Info: No load detected																																			
<i>Bit 14</i>	Warning: Regulator not stable ¹																																			
<i>Bit 15</i>	Warning: Short circuit ²																																			
<i>Bit 16</i>	Warning: Overtemperature ²																																			
<i>Bit 17</i>	Warning: Overcurrent ²																																			
<i>Bit 18</i>	Error: Flyback diode ³																																			
<i>Bit 19</i>	Error: High-side stuck on ³																																			
<i>Bit 20</i>	Error: High-side wiring ³																																			
<i>Bit 21</i>	Error: Bootup test failed ³																																			
<i>Bit 22</i>	Error: Delta summary current ³																																			
<i>Bit 23-27</i>	Reserved (0)																																			
<i>Bit 28-31</i>	Output number x. If mapped to a PDO, x will increase with 1 (up to 11 then back to 0 again) every time this entry is transmitted.																																			

- Note:
1. Only valid for current controlled outputs
 2. Output is temporarily disabled if this flag is set. The flag will automatically clear once the warning/error is gone.
 3. Output is permanently disabled if this flag is set. The flag will only be cleared if a power-cycle is performed.

Index	S-idx	Name	Type	Default	Description	Mappable	Saveable
0x5003	0x00	Sensor inputs	ro	u8	0x02	Number of sensor inputs (4-20mA)	
	0x01	Sensor input 1	ro	u16	-	Reports the current on sensor input 1 in μ A	x
	0x02	Sensor input 2	ro	u16	-	Reports the current on sensor input 2 in μ A	x
0x5004	0x00	Supply voltages	ro	u8	0x02	Number of supply voltages	
	0x01	VBB supply voltage	ro	u16	-	Input supply voltage to the VDM in mV	x
	0x02	Sensor supply voltage	ro	u16	-	Output supply voltage to the sensors in mV	x
0x5005	0x00	Internal temperature	ro	s8	-	Internal temperature in $^{\circ}$ C	x

15.3 CANopen EMCY objects

The following error codes are supported according to DSP-301 and DSP-401:

EMCY Code	Error register	Code	Description
0x8110	0x81	0x00 00 00 00 00	Error CAN, overrun
0x8130	0x81	0x00 00 00 00 00	Error heartbeat
0x8210	0x81	0x00 00 00 00 00	Error, PDO mismatch
0x8220	0x81	0x00 00 00 00 00	Error, PDO to long
0xFF00	0x81	0x00 00 00 00 00	Error, EEPROM
0xFF02	0x81	0x00 00 00 00 00	Error, IO-Init
0xFF03	0x81	0x01 00 00 00 00	Open circuit Output 1
		
		0x00 08 00 00 00	Open circuit Output 12
0xFF04	0x81	0x01 00 00 00 00	Short circuit Output 1
		
		0x00 08 00 00 00	Short circuit Output 12
0xFF06	0x81	0x00 00 00 00 00	Summary current delta
0xFF07	0x81	0x00 00 00 00 00	Regulator, output stuck high
0xFF08	0x81	0x00 00 00 00 00	Regulator, wiring error
0xFF09	0x81	0x00 00 00 00 00	High temperature
0xFF0A	0x81	0x00 00 00 00 00	High current low side
0xFF0B	0x81	0x00 00 00 00 00	Summary alarms, boot up test failed
0xFF0C	0x81	0x00 00 00 00 00	Error flyback diode
0xFF0D	0x81	0x00 00 00 00 00	Error, regulator not stable. Check PI-settings
0xFF0E	0x81	0x01 00 00 00 00	Undefined error during boot up test
		0x02 00 00 00 00	Fail after verifying that the differential amplifiers are reporting that no current is flowing
		0x04 00 00 00 00	Boot up test failed; low side stuck on
		0x08 00 00 00 00	Boot up test failed; low side stuck off
		0x10 00 00 00 00	Boot up test failed; current flows through low side mosfet
0xFF0E	0x81	0x20 00 00 00 00	Boot up test failed; current flows through low side mosfet
		0x40 00 00 00 00	Boot up test failed; BTS error state when outputs are off

		0x80 00 00 00 00	Boot up test failed; BTS error state when outputs are turned on
		0x00 01 00 00 00	Boot up test failed; BTS status fail when turned off
		0x00 02 00 00 00	Boot up test failed; BTS status fail when turned on
		0x00 04 00 00 00	Boot up test failed; Master / Slave status

16 Declaration of conformity CE



<i>Product name</i>	VDM12
<i>Product description</i>	Valve Driver Module with 12 PWM outputs. CAN bus I/O module.
<i>Manufacturer</i>	Electrum Automation AB
<i>Address</i>	Industrivägen 8, 901 30 Umeå, Sweden

The undersigned hereby declares on behalf of Electrum Automation AB, that the above reference product, to which this declaration relates, complies with the essential requirements of the following applicable **European Directives**, and carries the CE marking accordingly:

2011/65/EU	Restriction of the use of certain hazardous substances in electrical and electronic equipment
------------	---

And conforms with the following **Product Standards**:

CISPR 25	RF Emissions
ISO 11452-2	RF Immunity
ISO 11452-4	Bulk Current Injection
ISO 16750-2	Starting profile, load dump
ISO 7637-2	Transients
ISO 10605	ESD
EN 50581:2012	Technical documentation for the assessment of electrical and electronic products with respect to the restriction of hazardous substances

Person authorized to compile the technical file:

Thomas Moström
Electrum Automation
Industrivägen 8
901 30 Umeå
Sweden

2023-04-03

Date

Umeå, Sweden

Location



Thomas Moström
Design Manager
Electronic Production
Electrum Automation

17 Safety requirements for integrator to comply with

SREQ 0001	4
SREQ 0002	5
SREQ 0003	5
SREQ 0004	8
SREQ 0005	8
SREQ 0006	8
SREQ 0007	8
SREQ 0008	8
SREQ 0009	12

18 Document history

Document revision	Description	Release date
A	<ul style="list-style-type: none">Initial release	2022-06-14
B	<ul style="list-style-type: none">Changed EMC specification and populated DoC	2023-04-03

19 Contact us

For further information visit www.electrumab.se or contact us at info@electrumab.se.